



Bronto Skylift S70XT¹-J

UP, OVER AND BEYOND



Up, Over and Beyond

The new Bronto XT is Bronto's DNA perfected. When the job demands the best, Bronto XT delivers. The XT generation continues to build on the renowned standards of usability and high quality in Bronto aerial platforms. The first model of the new product generation is a Bronto S70XT¹-J. It offers superior usability in real-life worksite conditions and is a dependable performer that delivers precisely as promised.

The rigidity of the boom structure has been increased, while improving performance and without compromising the user experience Bronto operators have come to appreciate. The XT is a solid combination of the best features in older generations, complemented with practical improvements built on decades of product development and close collaboration with our customers. With a dependable reach for demanding tasks, it's built to take you up, over and beyond. The XT is ready for the challenge. Are you?

S70XT¹-J key features

- Increased usability, reliability and serviceability
- Enhanced up-and-over performance
- Best in class outreach with heavy loads
- Superior levelling capacity
- Improved sensor technology
- Modular cage structure
- Extendable cage with large cage rotation as a standard









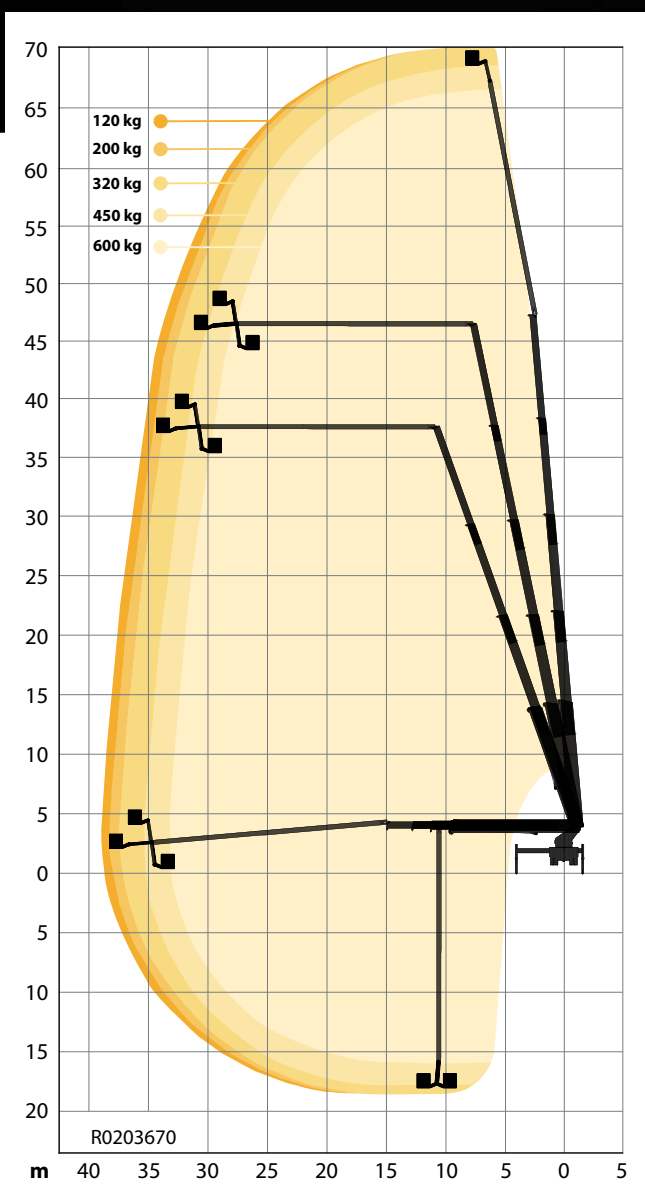
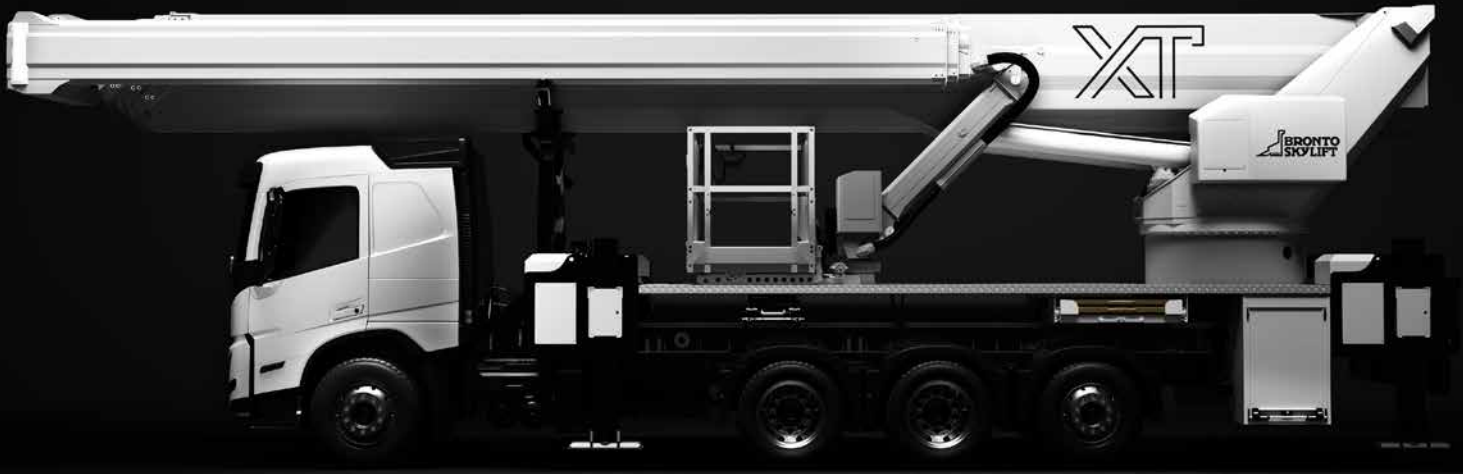



Best in class with heavy loads

The new S70XT¹-J features a 39-meter maximum outreach with 120kg and 33,2 meters with full 600kg cage load – making it the best in its class with heavy loads. In real-life conditions, aerial platforms are rarely used with minimum cage load and maximum outreach. That's why the XT offers extreme reach with bigger cage loads without compromising reliability, rigidity and stability.

In addition, the S70XT¹-J has a 3-section cage boom providing 24 meters of up & over reach – almost 10 meters more than the older generations. Large jib boom movement and +/-220 degrees cage rotation provide a flexible working envelope for versatile operations.



- 
70 m

1,1 x 2,4-3,7 m
- 
39 m

24 m
- 
68 m*

4 m*
- 
600 kg

12 m*
- 
+/- 220°

32 t*

Diagrams presented with standard cage and standard cage rotation. Variations apply.
 * depending on chassis

Real-life usability for different worksites

Functionality is improved with a modular cage structure with different openings and railings, 5 cage load options and of course, the trusted Bronto+ control system providing smooth movements and reliable outreach regardless of weather conditions.

The Bronto S70XT1-J offers superior jacking capacity with a longer outrigger stroke, which enables you to level the unit in rough, uneven ground, steep slopes and other demanding worksites without compromising on safety, reliability or reach.

As Brontos have a very long lifespan, the serviceability has not been forgotten in the design. For example, the modular cage design enables easier repair if railings are damaged and the overall accessibility to hydraulic components has been improved. More reliable and robust sensor technology and protected sensor placement reduce the overall service needs and lower the total cost of ownership.

All this adds up to superior usability in real-life worksite conditions – over all a dependable performer that delivers precisely as promised.

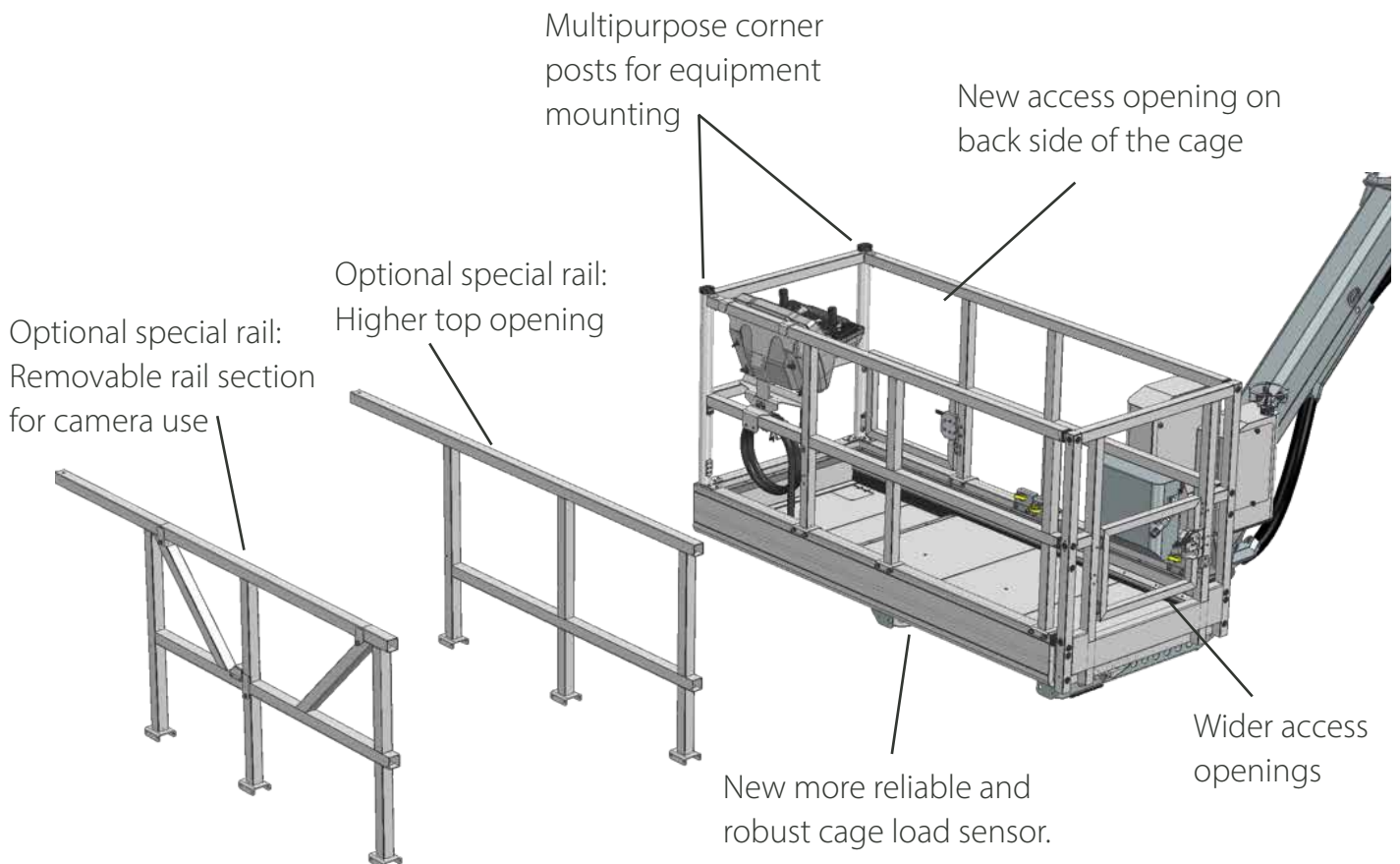



Optional equipment (simplified)

- Cage winch (max load 400 kg)
- Wireless remote control
- Additional emergency backup system
- Bronto Loadman
- Ultrasonic collision guard

Bronto One

More than fleet management

Bronto One is a cloud-based portal for managing fleets and operations – a single source for all critical information. It's your single point of entry to Bronto Skylift's lifecycle services, wherever you are.

Available in three levels, Basic, Plus and Pro, Bronto One includes features from fleet management, training, worksite planning, reporting and more to streamline your operations for best performance. Basic level is free for everyone with a Bronto aerial platform in their fleet.



Bronto One[®]

Basic

Plus

Pro

Bronto One Basic

Bronto One Basic provides you with an overview of your Brontos by consolidating basic unit information, manuals, info bulletins and service logs into one online hub. Get easy, instant access to these digital materials across your organisation – anytime, anywhere.

Bronto One Basic is free for all Bronto Skylift's customers.



Bronto One Plus

Bronto One Plus enables the usage data and analytics, as well as remote access to your aerial(s) for fast and accurate remote support. The usage data, analytics and insights help you reduce emissions, optimise fleet usage, and plan preventive services for maximum uptime.

Bronto One Plus is free during your warranty period.

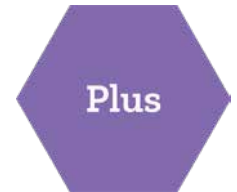

Bronto One Pro

Bronto One Pro includes all the features in Bronto One Plus but expands on them with a powerful suite of worksite management and planning tools. It makes worksite information easily available in the office and at the worksites and provides you with powerful 3D planning tool, Bronto Duties.



	Basic – Free	Plus	Pro
Basic unit info, Manuals, Bulletins, Service logs	x	x	x
Support centre	x	x	x
Remote access*		x	x
Fleet usage, analytics & insights**		x	x
Service plans		x	x
Worksite management and planning, incl. duties and available BIM models			x
Document management			x
Key benefits	<ul style="list-style-type: none"> • Bronto unit information • Manuals, service logs and info bulletins • Support centre 	<ul style="list-style-type: none"> • Remote access • Usage data, analytics, insights • Training management 	<ul style="list-style-type: none"> • Worksite management • 3D worksite planning • Document management

* Only to units with Bronto+ control system

** Only for Bronto 4+ & Bronto 5+ control systems



Up, Over and Beyond

Bronto Skylift is a trusted global supplier of truck-mounted hydraulic platforms. We design, manufacture, sell and service appliances for rescue and firefighting as well as for construction work.

Our product range includes approximately 50 models with a range of 17 to 112 metres of working height. The advanced modularity also allows for numerous client-specific modifications. During the past 50 years, we have delivered over 7,000 platform units to fire brigades and industrial customers throughout all the continents in more than 120 countries.

Our headquarters and production plants are situated in Finland. We also have subsidiaries in Germany, Sweden, Switzerland and the US. The company is part of the Japan-based Morita Holdings Corporation.

sales@brontoskylift.com

Technical data and illustrations subject to change without notice.

www.brontoskylift.com